

CLASSIC II

Deli/Pastry/Chocolate Showcase

CLASSIC II DELI/PASTRY/CHOCOLATE

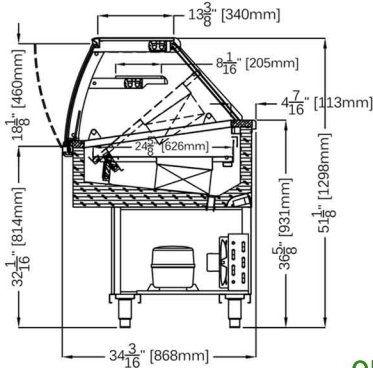

OPTIONAL: COLD STORAGE

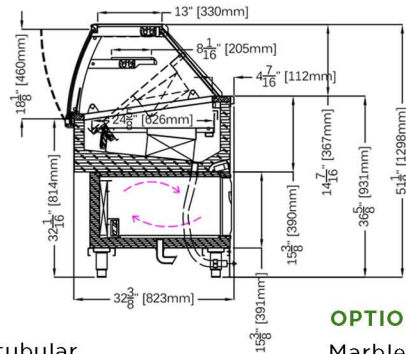

STANDARD FEATURES

- Stainless steel insulated body with tubular painted galvanized chassis
- Silver trim finish
- Dixell digital controller
- Air cooled condensing unit
- Temperature front and side glass single pane with anti-fog serigraph
- Tilt back front glass
- LED lighting
- Plexiglass sliding doors
- Stainless steel work bench
- Pastry with drawer (static refrigeration)
- Cases ship standard unfinished front and stainless steel skin sides

OPTIONS

- Marble/Granite work counter
- RAL color finish/wood laminate
- Champagne trim finish
- Roll down curtain
- Remote/water cooled unit
- Matching front cabinetry counters with top glass
- Canopy lighting
- Stainless steel step up deck shelf
- Cold storage option with static refrigeration and separate control
- Casters

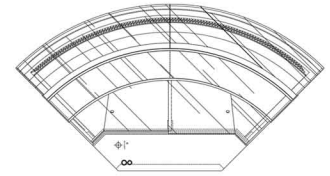

90° Open Corner

CLASSIC II DELI/PASTRY/CHOCOLATE						
TECHNICAL FEATURES		MODELS				
		CLASSIC II CIIDPC900	CLASSIC II CIIDPC1300	CLASSIC II CIIDPC1700	CLASSIC II CIIDPC2106	CLASSIC II CIIDPCA90
External Dimensions (L-D-H)	Inches	35 7/16" - 34 3/16" - 51 1/8"	51 3/16" - 34 3/16" - 51 1/8"	66 15/16" - 34 3/16" - 51 1/8"	82 15/16" - 34 3/16" - 51 1/8"	80 7/8" - 34 3/16" - 51 1/8"
	Inches-MM	900 - 868 - 1298	1300 - 868 - 1298	1700 - 868 - 1298	2106 - 868 - 1298	2055 - 868 - 1298
Crated Dimensions (L-D-H)	Inches	43 1/3" - 39 3/8" - 55 1/8"	59" - 39 3/8" - 55 1/8"	74 7/8" - 39 3/8" - 55 1/8"	90 1/2" - 39 3/8" - 55 1/8"	87" - 45" - 55 1/8"
	Inches-MM	1100 - 1000 - 1400	1500 - 1000 - 1400	1900 - 1000 - 1400	2300 - 1000 - 1400	2209 - 1143 - 1400
Compressor	Nr./Type	1 / Hermetic	1 / Hermetic	1 / Hermetic	1 / Hermetic	1 / Hermetic
BTU'S @ +14°F Evap						
Temperature (+35°F Chocolate)	BTU'S	2350 BTU'S	2945 BTU'S	3450 BTU'S	3975 BTU'S	2940 BTU'S
		230/1/50 (EU)	230/1/50 (EU)	230/1/50 (EU)	230/1/50 (EU)	230/1/50 (EU)
Electric Supply*	(V/Ph/Hz)	120/1/60 (USA)	120/1/60 (USA)	120/1/60 (USA)	120/1/60 (USA)	120/1/60 (USA)
Power Consumption	(W/A)	565W / 5.5A	680W / 6A	885W / 6.5A	885W / 7.5A	885W / 5.5A
Deck Operating Temperature*	°F	39°F	39°F	39°F	39°F	39°F
Net Weights	Kg/Lb	94Kgs / 216Lbs	118Kgs / 271Lbs	130Kgs / 299Lbs	180Kgs / 396Lbs	140Kgs / 308Lbs
Crated Weights	Kg/Lb	110Kgs / 253Lbs	138Kgs / 318Lbs	155Kgs / 356Lbs	205Kgs / 451Lbs	175Kgs / 385Lbs

* Dimensions are without side panels

* Any and all shelves above the deck will NOT be refrigerated on these models

* Chocolate 220V

* Manufacturer reserves the right to change specifications without notice. Not responsible for error and omissions.



361-367 Beach Road, Burlingame, CA 94010
 Tel: 855.885.2400 | 650.342.2400 | Fax: 650.342.7400
 sales@oscartek.com | www.oscartek.com

