

# CLASSIC

## Chocolate Showcase

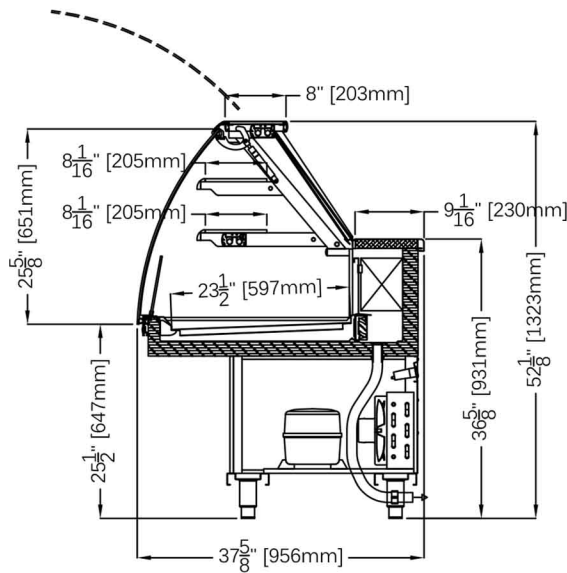

Photo shown is with optional front finish and champagne trim finish. Standard cases are silver trim finish, unfinished front, and stainless steel skin sides

### STANDARD FEATURES

- Stainless steel insulated body with tubular painted galvanized chassis
- Silver trim finish
- Dixell digital controller
- Air cooled condensing unit
- Temperature front and side glass single pane with anti-fog serigraph
- Lift up hydraulic front glass
- LED lighting
- Plexiglass sliding doors
- Stainless steel work bench
- Humidity control system
- Cases ship standard unfinished front and stainless steel skin sides

### OPTIONS

- Marble/Granite work counter
- RAL color finish/wood laminate
- Champagne trim finish
- Roll down curtain
- Remote/water cooled unit
- Matching front cabinetry counters with top glass
- Stainless steel step up deck shelf
- Cold storage option with static refrigeration and separate control
- Casters

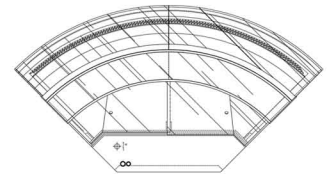

90° Open Corner

CLASSIC CHOCOLATE							
TECHNICAL FEATURES		MODELS					
		CLASSIC CC1000	CLASSIC CC1500	CLASSIC CC2000	CLASSIC CC2500	CLASSIC CC3000	CLASSIC CCA90
External Dimensions (L-D-H)	Inches	39 1/2" - 37 3/4" - 52 1/8"	59 1/8" - 37 3/4" - 52 1/8"	78 3/4" - 37 3/4" - 52 1/8"	98 1/2" - 37 3/4" - 52 1/8"	118 1/4" - 37 3/4" - 52 1/8"	80 1/16" - 37 3/4" - 52 1/8"
	MM	1000 - 956 - 1323	1500 - 956 - 1323	2000 - 956 - 1323	2500 - 956 - 1323	3000 - 956 - 1323	2034 - 956 - 1323
Crated Dimensions (L-D-H)	Inches	44" - 42 1/2" - 57"	65" - 42 1/4" - 57"	84 3/4" - 42 1/4" - 57"	102 3/4" - 42 1/4" - 57"	122 3/4" - 42 1/4" - 57"	86" - 42 1/4" - 57"
	MM	1100 - 1056 - 1447	1600 - 1056 - 1447	2100 - 1056 - 1447	2600 - 1056 - 1447	3100 - 1056 - 1447	2184 - 1056 - 1447
Power Supply	(V)	220V	220V	220V	220V	220V	220V
BTU'S @ +35°F Evap Temperature	BTU'S	1600 BTU'S	2016 BTU'S	2560 BTU'S	3072 BTU'S	3072 BTU'S	2400 BTU'S
Amperage	(A)	5A	5.5A	8.5A	8.6A	11A	5A
Humidity Control*	%	35-75%	35-75%	35-75%	35-75%	35-75%	35-75%
Deck Operating Temperature*	°F	57°F	57°F	57°F	57°F	57°F	57°F
Net Weights	Kg/Lb	147Kgs / 323Lbs	186Kgs / 410Lbs	224Kgs / 492Lbs	271Kgs / 596Lbs	314Kgs / 722Lbs	186Kgs / 410Lbs
Crated Weights	Kg/Lb	157Kgs / 297Lbs	200Kgs / 440Lbs	239Kgs / 526Lbs	291Kgs / 640Lbs	334Kgs / 734Lbs	200Kgs / 440Lbs

\* Dimensions are without side panels

\* Any and all shelves above the deck will NOT be refrigerated on these models

\* Manufacturer reserves the right to change specifications without notice. Not responsible for error and omissions.



361-367 Beach Road, Burlingame, CA 94010  
 Tel: 855.885.2400 | 650.342.2400 | Fax: 650.342.7400  
 sales@oscartek.com | www.oscartek.com

