

## STANDARD FEATURES

- Energy efficient air cooled condensing unit
- One piece molded body using 3" ecologic polyurethane insulation
- High performance
- Static refrigeration with embedded coil and thermostatic valve
- Climate class 4 (+86°F/55% R.H.)
- AISI304 stainless steel external finish top and back stainless interior
- Ecological polyurethane foam insulation
- Stainless steel scotch brite adjustable feet, gray steel frame support
- Digital control panel
- Flexible arrangement can be multiplexed and customized to fit customer layout
- 240oz. stainless steel container; Stainless steel cylindrical containers dim. Ø 7 1/2"-9 3/4"H.
- Approximately 7 liters
- Cases ship standard unfinished



## OPTIONS

- Sneeze guard
- Water cooled condensing system
- Remote condensing unit
- Electric heated condensate pan
- Custom front and side paneling
- Stainless steel scoop washer with fixed water tap
- Reinforced wood crate
- Casters



Custom stone top and stone clad lids

## POZZETTI/BPGL WITHOUT STORAGE

TECHNICAL FEATURES		MODELS			
		POZZETTI/BPGL P2	POZZETTI/BPGL P4	POZZETTI/BPGL P6	POZZETTI/BPGL P8
External dimensions (L-D-H)	Inches	*19 11/16" - 25 13/16" - 36 5/8"	*29 1/2" - 25 13/16" - 36 5/8"	*39 3/8" - 25 13/16" - 36 5/8"	*49 3/16" - 25 13/16" - 36 5/8"
	Inches-MM	*500 - 655 - 931	*750 - 655 - 931	*1000 - 655 - 931	*1250 - 655 - 931
Crated dimensions (L-D-H)	Inches	25" - 31" - 42"	35" - 31" - 42"	45" - 31" - 42"	55" - 31" - 42"
	Inches-MM	635 - 787 - 1066	889 - 787 - 1066	1143 - 787 - 1066	1397 - 787 - 1066
Refrigeration	Type	Static	Static	Static	Static
No. of Containers (240 oz.)	#	2	4	6	8
Compressor	Nr./Type	1	1	1	1
Compressor	(Pw-HP)	230-1/3	230-1/3	310-5/8	310-5/8
BTU's @ -25°F Evap	BTU'S	832 BTU'S	1280 BTU'S	2048 BTU'S	2528 BTU'S
Power Supply	(V/Ph/Hz)	115/1/60	115/1/60	115/1/60	115/1/60
Electrical Input (standard)	(W/A)	5.1A	5.2A	7.3A	7.5A
Defrost	Mode/Type	Off-Cycle	Off-Cycle	Off-Cycle	Off-Cycle
Climatic Class	N°/°C/F°/H.R.	4	4	4	4
Operating Conditions	---	55	55	55	55
Refrigerant	Type	R404A	R404A	R404A	R404A
Net Weights	Lb	200Lbs	260Lbs	330Lbs	419Lbs
Crated Weights	Lb	350Lbs	469Lbs	573Lbs	694Lbs

\* DIMENSIONS ARE WITHOUT SIDE PANELS

\* Manufacturer reserves the right to change specifications without notice. Not responsible for error and omissions.



512 South Airport Blvd., South San Francisco, CA 94080  
 Tel: 855.885.2400 | 650.342.2400 | Fax: 650.342.7400  
 sales@oscartek.com | www.oscartek.com



POZZETTI/BPGL WITHOUT STORAGE				
TECHNICAL FEATURES		MODELS		
		POZZETTI/BPGL P10	POZZETTI/BPGL P12	POZZETTI/BPGL PA45
External dimensions (L-D-H)	Inches	*59 3/8" - 25 13/16" - 36 5/8"	*78 3/4" - 25 13/16" - 36 5/8"	*44 1/6" - 25 13/16" - 36 5/8"
Inches-MM	MM	*1507 - 655 - 931	*2000 - 655 - 931	*1120 - 655 - 931
Crated dimensions (L-D-H)	Inches	65" - 31" - 42"	85" - 31" - 42"	51" - 31" - 42"
Inches-MM	MM	1651 - 787 - 1066	2159 - 787 - 1066	1295 - 787 - 1066
Refrigeration	Type	Static	Static	Static
No. of Containers (240 oz.)	#	10	12	5
Compressor	Nr./Type	1	1 (2)	1
Compressor	(Pw-HP)	310-5/8	310-5/8	310-5/8
BTU's @ -25°F Evap Temperature	BTU'S	3200 BTU'S	4096 BTU'S	2528 BTU'S
Power Supply	(V/Ph/Hz)	115/1/60	115/1/60 (2)	115/1/60
Electrical Input (standard)	(W/A)	7.7A	7.3A (2)	8A
Defrost	Mode/Type	Off-Cycle	Off-Cycle	Off-Cycle
Climatic Class	N°/°C/F°/H.R.	4	4	4
Operating Conditions	---	55	55	55
Refrigerant	Type	R404A	R404A	R404A
Net Weights	Lb	508Lbs	660Lbs	419Lbs
Crated Weights	Lb	764Lbs	1146Lbs	694Lbs

\* DIMENSIONS ARE WITHOUT SIDE PANELS

### OPTIONAL: SNEEZE GUARD SECTION VIEW

### STANDARD SECTION VIEW

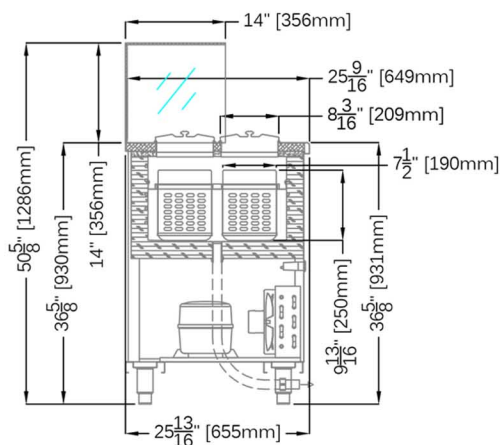
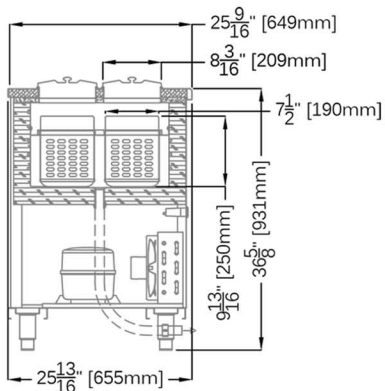

\* Manufacturer reserves the right to change specifications without notice. Not responsible for error and omissions.



512 South Airport Blvd., South San Francisco, CA 94080  
Tel: 855.885.2400 | 650.342.2400 | Fax: 650.342.7400  
sales@oscartek.com | www.oscartek.com



## PLAN VIEWS

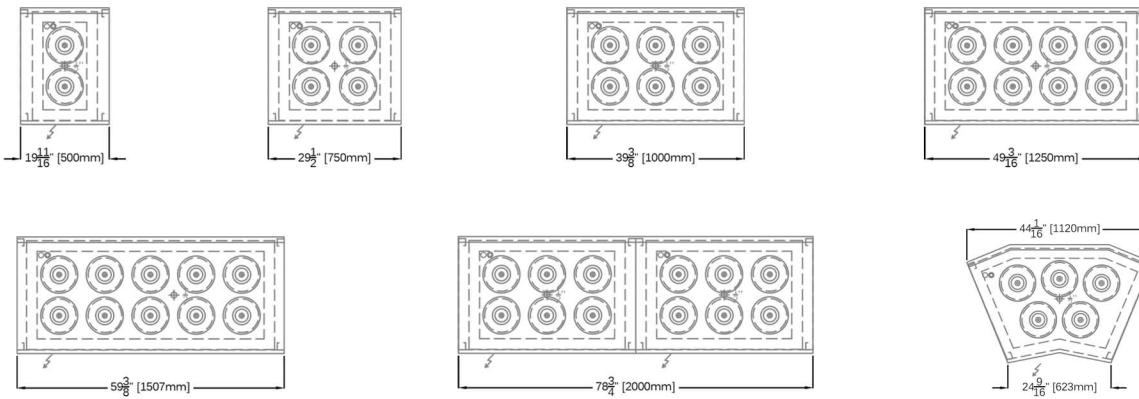

## REAR ELEVATION (OPERATOR SIDE)

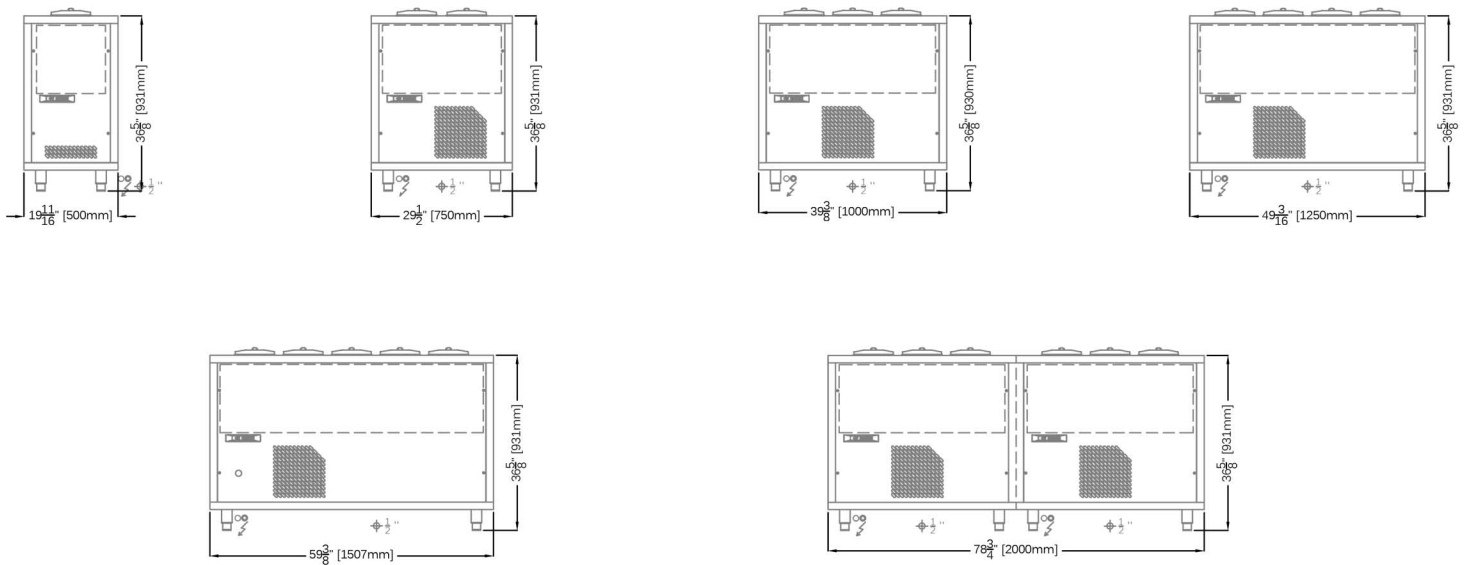

\* Manufacturer reserves the right to change specifications without notice. Not responsible for error and omissions.